



pbq Batteries

VRLA General Information

GENERAL FEATURES

High Quality & Reliability

The **pbq** VRLA battery has a constant and reliable performance. It can be easily maintained to provide proper operation of the equipment that it powers.

Sealed Construction

pbq's reliable construction and sealing technique guarantee that no electrolyte leakage can occur from the terminals or the case of any **pbq** battery. This feature ensures safe, efficient operation of **pbq** batteries in any orientation. **pbq** batteries are classified as "Non-Spillable" and meet all requirements of the International Air Transport Association.

Long Service Life, Float or Cyclic

The **pbq** VRLA battery has long life in float or cyclic service. The expected life of float service is 5, 10 or 15 years depending on the model and working temperature. The expected life of cyclic service can reach up to 1.300 cycles depending on the depth of discharge (DoD).

Maintenance-Free Operation

During the expected float service life of **pbq** batteries, there is no need to check the specific gravity of the electrolyte, or add water. In fact, there is no provision for these maintenance functions to be carried out.

Low Pressure Venting System

pbq batteries are equipped with a safe, low pressure venting system, which operates between 1psi and 6psi, designed to release excess gas and reseal automatically in the event that gas pressure rises to a level above the normal rate. Thus, there is no excessive build-up of gas in the batteries. This low pressure venting system, coupled with the extraordinarily high recombination efficiency, make **pbq** batteries very safe.

Heavy Duty Grids

The heavy-duty lead calcium-alloy grids in **pbq** batteries provide an extra margin of performance and service life in both float and cyclic applications, even in conditions of deep discharge.

Low Self Discharge

Because of the use of Lead Calcium in the manufacture of the grid alloy, charged **pbq** batteries can be stored for relatively long periods of time without requiring to be recharged.

U.L. Component Recognition

Many of our **pbq** VRLA batteries have passed UL tests.

APPLICATIONS

A **partial list** of some of the more common applications includes, but is not limited to, standby or primary power for:

- Alarm Systems
- Marine Equipment
- Cable Television
- Medical Equipment
- Communications Equipment
- Micro Processor Based Control Equipment
- Office machines
- Electronic Cash Registers
- Electronic Test Equipment
- Solar Powered Systems
- Electric powered Bicycle and Wheelchairs
- Telecommunications
- Emergency Lights
- Fire & Security Systems
- Vending Machines
- Toys
- Geophysical Equipment
- Power Tools
- Uninterruptible Power Supplies (UPS)
- Wheelchairs
- Elevators



***pbq** factories where the environment and state-of-the-art production go hand in hand*

TECHNICAL TERMS

1. Battery capacity for small VRLA batteries, accepted by worldwide convention, is described in "Ampere Hour" at the 20-hour rate (C_{20}) when discharged at 25°C. For a **pbq** 4-12 at C_{20} this battery will deliver a current of 200mA during 20 hours to a cut-off voltage of 1.75 volts per cell (10.5 volts per battery). Please note that for some larger **pbq** batteries the capacity is shown for a discharge time over 10 hours (C_{10}).
2. Battery load, by convention is described in terms of a multiple of C, in amperes, where C is the capacity at 25°C, so for a 4.5Ah battery 1C equals 4.5A while 2C equals 9A.
3. Battery cut-off voltage is the voltage per cell to which a battery may be discharged safely to maximize battery life, this data is specified according to the actual discharge load and run time. As a rule of thumb, a VRLA battery will tolerate a lower cut-off voltage, without being damaged, at high current loads and short run times e.g at 2C, the voltage can drop to 1.35Vpc compared with a cut-off voltage of 1.75Vpc when discharged at its 20 hour rate of 0,05C.
4. Voc = Open Circuit Voltage or the voltage of a battery without any load attached other than a high impedance multi-meter or similar device.
5. Vpc = Voltage per cell. Each cell in a lead acid battery generates around 2 volt. Therefore, a 6 volt lead acid battery is build by connecting 3 cells in series while a 12 volt battery is made of 6 cells. Multiply the number of cells with the voltage indicated in the formulas and other examples given in this technical manual to calculate the battery voltage.
6. A cell is a single electrochemical combination generating a certain voltage, 2 volt for a lead acid, while a battery is a combination of 2 or more cells. However, in everyday speech, one usually refers to batteries even if it is actually a cell.



Soldering the battery plates

BATTERY STORAGE

It is recognized that **pbq** VRLA batteries exhibit excellent charge retention characteristics. That is, their self discharge rate is low and is typically less than 3% per month at 25°C. Although the self discharge rate is low, specific precautions must be taken to guard against the battery over discharging due to self discharge when in storage or in a non operational mode.

It is necessary to understand what is meant by a fully discharged (flat) battery. A discharged battery may be determined by the voltage of that battery. The voltage of a battery that can be described as fully discharged varies with the discharge current. For example, the higher the discharge current for a battery, the quicker the battery reaches a fully discharged state and the lower the voltage will be for a battery to be described as fully discharged (flat). At all times, to prolong its active life, a VRLA battery should be recharged immediately after it has been either partially or fully discharged,

Storage temperature for VRLA batteries

The **pbq** batteries can be stored in an ambient temperature of between -35°C to +50°C.

Mechanical precautions

Storage at low temperatures is possible providing the battery is handled with some extra care, since most plastics hardens at low temperatures, the risk of damaging the battery container through shock or dropping will increase. When stored at high temperatures ensure that the battery is on a flat and horizontal shelf to prevent deformation of the plastic container.



Assembled plates

Electrical precautions

Note that the electrochemical processes in any battery will be influenced by the temperature. When taking a battery out of storage ensure proper functioning before connecting it to your equipment. Check that the delivered voltage and current drain of your applications meets the specifications at the given temperature. The electric characteristics will be reduced at low temperatures, so in order to reach the full capacity, let the battery warm up before use.

Storage at different temperatures will influence the self discharge. If the temperatures is below 20°C every 9 months the battery should be checked and recharged, above 30°C this should be done every 3 months. Storage at temperatures above 40°C will reduce the functional life of the battery. When

charging batteries that are stored at temperatures other than room temperature, a charger that accordingly compensates the charge voltage should be used.

The slowest practical rate of discharge for a lead acid battery is self discharge. As the current is very low, the fully discharged voltage is high, i.e. the battery is flat at 2.00 – 2.03Vpc. Therefore a program of stock control must be introduced to ensure that batteries are recharged well before that voltage is reached. A FIFO usage system is also recommended.

Supplementary Charge Advice

- Storage Temperature Charging Interval
- 20°C or less Every 9 months
- 20 - 30°C Every 6 months
- 30 - 40°C Every 3 months

While discharging a battery, lead sulphate (sulphation) is formed. If the battery is recharged as soon as discharging is completed, the lead sulphate is converted to active material. However, on self discharge the lead sulphate that is formed may become inactive, so that it cannot be reconverted. The lower the voltage that a battery is allowed to fall under when self discharging, the more likely it is that the sulphation formed will not be able to be reversed. The battery will be "damaged beyond recovery".

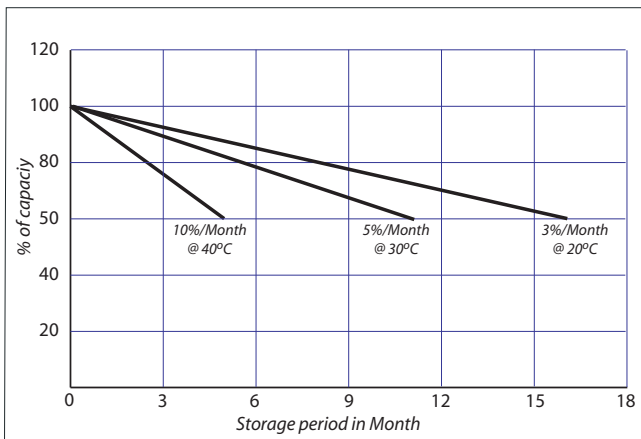

Precautions Against Over Self Discharge

- **Never** subject batteries to an external heat source.
- **Always** store batteries in a cool, dry place
- **Never** store batteries in direct sunlight.
- **Always** regularly check the voltage of batteries in stock.

Precautions for Pre-Installed Batteries

When batteries are installed in a product the following precautions to avoid over discharge during storage must be taken:

- Only new or freshly recharged batteries should be used.
- Any load that is on the battery in the product must be FULLY DISCONNECTED. Any discharge on the battery other than self-discharge will quickly flatten the battery and cause formation of lead sulphate which, if left in this state for too long, will irreversibly damage the battery.
- The first operating instruction for equipment fitted and sold with a rechargeable lead acid battery must be: "The battery must be fully charged before use.
- Do not mix batteries with different capacities and/or production dates in a single application.
- Do not connect more than four batteries or strings of batteries in parallel without consulting a pbq engineer.

Extremely Low Temperatures

The pbq VRLA batteries can be exposed to sub-zero (°C) temperatures without serious damage. However, if they get frozen, there may be damage to the active material of the plates so premature loss of capacity can occur. Charging a "frozen" battery can result in localized high current densities and heating of the plates which will result in additional damage.

The charging voltage should be temperature compensated when temperature extremes are anticipated. The maximum voltage to be allowed at cold temperature is 2.5 volts per cell while the minimum voltage allowed at high temperatures is 2.17 volts per cell. Constant current charging schemes should not be used.

Electrolyte Freezing

Water, with a specific gravity of 1.0gr/cm³ will freeze at 0°C. The electrolyte in a fully charged pbq VRLA battery, with a specific gravity of 1.280 to 1.300gr/cm³, will not freeze until a temperature of -71°C is reached. Obviously it is unlikely that the fully charged VRLA battery will be frozen.

However, a long period with a low rate discharge of a typical VRLA battery can result in an electrolyte specific gravity of less than 1.1gr/cm³. This discharged condition could lead to an electrolyte that would then freeze at approximately -7°C.

Therefore, always charge batteries 100% when extreme low temperatures are expected and never leave discharged batteries at low temperatures. When charging a battery that has been stored in a discharged state at low temperatures, make sure that the battery is fully warmed to room temperature before charging the battery.

Recharging a Self Discharging Battery

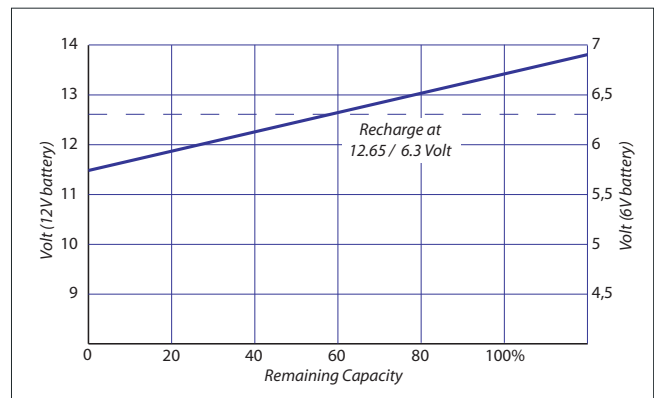

When it becomes necessary to give a self discharged battery a "top up" charge, the following procedures should be observed:

1. Ensure the Voc of the battery is greater than 2Vpc. If the voltage is lower than 2Vpc please refer the problem to your pbq distributor before attempting to recharge.
2. Constant voltage charging recommended.

Less than 6 months from manufacture or previous top up charge: Maximum of 20 hours at a constant voltage of 2.4Vpc.
Up to 12 months after manufacture or previous top up charge: Maximum of 24 hours at a constant voltage of 2.4Vpc.

Note: A faster recharge may be obtained by using the constant current method of charging. However, this requires a closer supervision of the charging procedures.

Less than 6 months from manufacture or previous top up charge: Maximum of 6 hours at a constant current of 0.1C.

Up to 12 months after manufacture or previous top up charge: Maximum of 10 hours at a constant current of 0.1
Placing the cells in the containers



DISCHARGE CHARACTERISTICS

General Comments

The discharge curves show the minimum design parameters for each fully charged **pbq** battery after installation. Full capacity is reached after initial service as follows:

- Float Service:
- One month after installation and recharging.
- Cycle Service:
- Within three to five cycles after initial charge and service entry.

The discharge capacity of a VRLA battery varies and is dependent on the discharge current. **pbq** VRLA batteries are normally rated at their 20 hour discharge rate. i.e. The current that the battery can supply during 20 hours, discharged to an end voltage of 1.75Vpc at a temperature of 25°C. Some models are rated at a 10 hour discharge rate indicated at the individual data sheet.

The faster a battery is discharged, the less capacity it will deliver. Please note that a faster discharge at a higher current will allow a lower cut-off voltage. Repeatedly discharging a battery to a low cut-off voltage during a slow, low current, discharge will reduce the functional life due to over-discharging and could result in deformation of the battery.

As can be seen in the table below, the gain in capacity is relatively small when discharging down to low cut-off voltages during long discharges. It is therefore not recommended to discharge the battery into the hatched areas of the tables since this could result into reduced functional life and battery deformation.

Discharge data Watt/cell

	Discharge time	5 min	10 min	15 min	30 min	1 hr	3 hr	5 hr
End Voltage	10,80	41	26	22	13	8	3,6	2,6
	10,50	44	28	23	14	9	3,7	2,7
	10,20	47	30	25	14	9	3,8	2,8
	9,90	51	32	26	15	10	3,9	2,8
	9,60	54	34	28	16	10	4,0	2,9

BATTERY SELECTION

The battery discharge graphs on the individual data sheets can be used for battery selection. The data sheets show the actual ampere hour capacity of each battery type at various discharge currents and cut-off voltages. It is suggested that a review is made together with your pbq distribution partner in case of any questions.

Effect of Temperature on Battery Capacity

The nominal battery capacity is based on the temperature of 25°C. Above this temperature the capacity increases marginally but it must be noted that the working battery should be kept within the temperature design limitations of the product. Below 25°C the capacity decreases. This decrease in capacity becomes large at temperatures below 0°C and at high discharge rates.

The graph illustrates the situation and the decrease in capacity with the decrease in operating temperature. Temperature must be taken into capacity design calculations in applications where the operating temperature of the system is below 20°C.

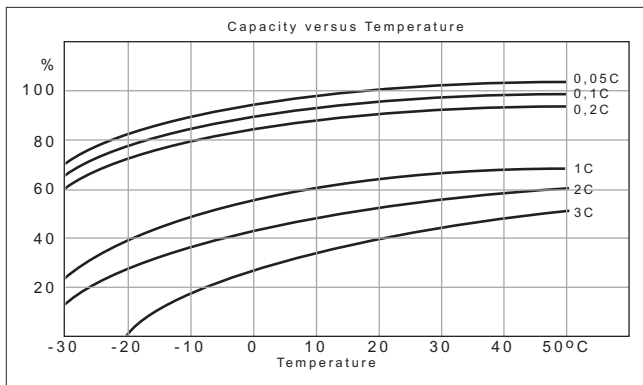

Electrolyte filling of the battery

BATTERY CHARGING

Correct battery charging ensures the maximum possible working life for the battery. There are three major methods of charging:

- Constant Voltage / Constant Current CV/CC Charging
- Two or Three Stage Constant Voltage Charging
- Taper Current Charging.

Constant Voltage / Constant Current Charging

This is the recommended method of charging, also known as CC/CV charging, for VRLA batteries. It is necessary to closely control the actual voltage to ensure that it is within the limits advised:

- Float service: 2.27 – 2.30Vpc at 25°C.
(13.6 - 13.8V for a 12V and 6.8 - 6.9V for a 6V battery)
- Cycle service: 2.42 – 2.48Vpc at 25°C.
(14.5 - 14.9V for a 12V and 7.25 - 7.45V for a 6V battery)

It is suggested that the initial current will be set at 0.3C or lower.

Because the battery is not 100% efficient, it is necessary to charge a greater amount of energy into the battery than what was taken out of the battery on discharge. With a "good" or new VRLA battery, the actual value of the decreasing current, indicating that the battery is fully charged, is approx 5mA/Ah when a constant voltage charge of 2.30Vpc is applied.

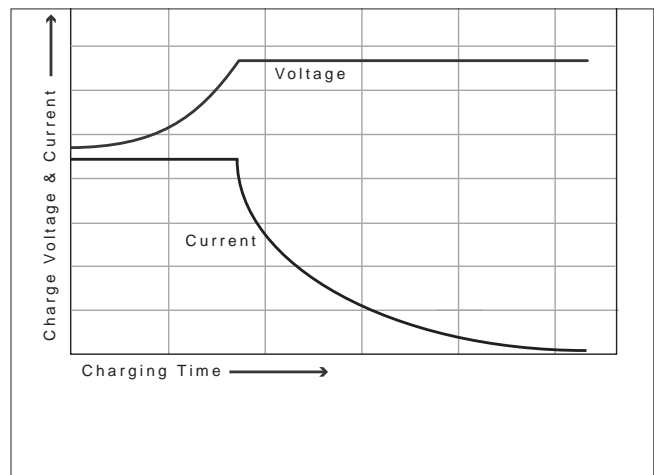

Note: It is necessary to ensure that the voltage is correctly set. When the charging voltage is set too high the corrosion of the positive plates will increase and shorten the battery life. A charging voltage which is set too low will lead to sulphation of the plates causing loss of capacity and ultimately shortening the life of the battery.

Two or Three Stage Constant Voltage Charging

This method can be used where the battery and load are connected in parallel. An intelligent charger detects when the current flowing through the battery drops below a certain threshold and then switches to a lower charge voltage resulting in a reduced charge current. The advantages are faster recharge than during CC/CV charging however, one must assure that the connected device can function safely with the higher charge voltage during the beginning of the charge. This charge voltage usually is 14.5 - 14.9V for a single 12 Volt battery.

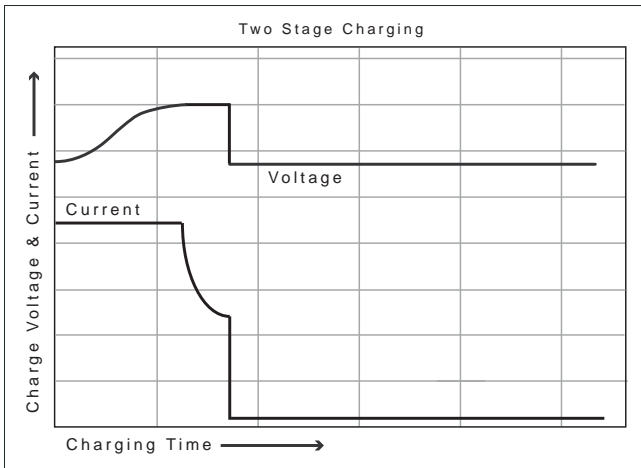

Taper Current Charging

This method is not recommended for VRLA batteries, however, if this method is to be used it is suggested that the pbq distributor's technical department is contacted.

Constant Current Charging

This method of charging is generally not recommended for VRLA batteries. It is necessary to understand that, if the batteries are not removed from the charger as soon as possible after reaching a state of full charge, considerable damage will occur to the batteries due to overcharging.

Effect of Temperature on Charging Voltage

As temperature rises, electrochemical activity in a battery increases. Similarly, as temperature falls, electrochemical activity decreases. Therefore, conversely, as temperature rises charging voltage should be reduced to prevent overcharge, and increased as temperature falls to avoid undercharge. In general (especially where battery temperature changes are greater than 25°C ± 5°C), to assure optimum service life, the use of a temperature compensated charger is recommended.

The recommended compensation factor for pbq batteries is:

- -3mV/°C/Cell (stand by) and
- - 4mV/°C/Cell (cyclic use)

The standard centre point for temperature compensation is 25°C. The figure shows the relationship between temperatures and charging voltages in both cyclic and standby applications.

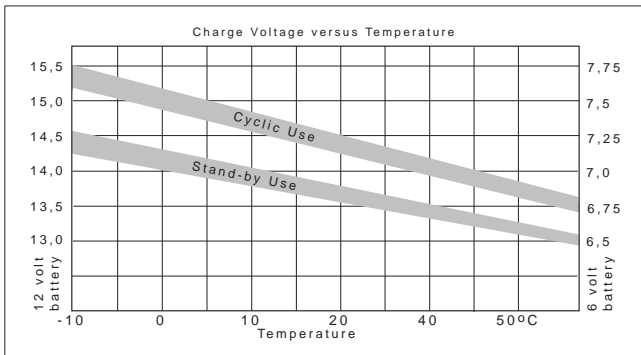

Effect of Voltage on battery Gassing

The pbq VRLA battery is designed to provide more than 99% recombination under normal charging conditions. Therefore they can be in occupied areas without concern for a hazardous build-up of hydrogen gas. Only when a charge voltage is used

that is higher than recommended, pressure build-up can occur resulting in opening of the vents and release of gasses.

Important in order to minimize the gas emitted from the VRLA battery is the use of the proper float charging voltage of between 2.27 and 2.30 volts per cell and limited use of the equalization voltage of 2.4 volts per cell. As the charging voltage per cell is increased above 2.3 volts per cell the gassing rate increases dramatically.

A pbq 26Ah battery will generate approximately 2.9cc per hour of hydrogen when recharged at 2.3 Volt per cell but will generate double this quantity at a charge voltage of 2.4 volt.

A pbq 100Ah battery will generate approximately 9cc per hour at 2.3 Volt per cell and 18cc per hour at 2.4 Volt per cell. As a guideline the gassing rate at 2.3 volts per cell is approximately 0.0185 cc/hr/Ah/cell. This maintains within the limit of the battery vents. However, this rate could increase by a factor of 20 or more at 2.5 Volt per cell resulting in over-pressure, opening of the vents and gass release.

The lower the charging voltage, such that the standby capacity of the battery can be maintained, the lower the gassing rate of the battery will be.

Ventilation Requirements

It is advisable to calculate the actual gas emissions to be expected from a battery system and the required air exchanges to prevent an accumulation of hydrogen. Please check the local requirements and regulations to ensure the safety of the installation. Calculate the gassing based on the average hydrogen production for the batteries and adjust ventilation accordingly. Base this on the unoccupied volume of the battery room to calculate the air exchange rate needed to reach a maximum 2% of hydrogen.

The following recommendations show general guidelines to minimize gassing and assure safety of the installation:

- Float charge the pbq VRLA battery at the recommended 2.27 to 2.30 Volt per cell average at 25°C.
- Adjust the float charging voltage in accordance to the requirements of operating temperatures other than 25°C when the ambient is expected to be more than 5°C different from this temperature.
- Use a temperature compensated charging voltage if frequent variations of the ambient are expected.
- Do not charge the pbq VRLA battery at temperatures above 50°C.
- Make sure there is free flow of air around the individual batteries (10mm spacing between batteries).
- Natural or forced ventilation of the battery area to avoid any accumulation of gas over long periods of time is recommended.
- Calculate the expected build-up of hydrogen gas within the battery area and the safety margin.

AC Ripple Voltage and Current Limitations

When using simple chargers check the AC ripple since this can have a major impact on battery life. If the DC charging voltage contains an AC ripple voltage (V_{rms}) an AC ripple current (I_{rms}) will flow through the battery in addition to the normal DC charging current.

The charger output maximum allowable AC ripple voltage (V_{rms}) is:

- Cyclic service: 1,5% of DC Charging Voltage
- Float service: 0,5% of DC Float Charging Voltage

Due to the low internal resistance (R_i) of the battery, the resulting AC ripple current can be very large, up to 100 times as large as the DC float current and result in significant heating ($I_{rms}^2 R_i$) of the battery. Since the battery service life is reduced by 50% for every 10°C above its rated operating temperature of 25°C, any long term increase in its temperature should be avoided.

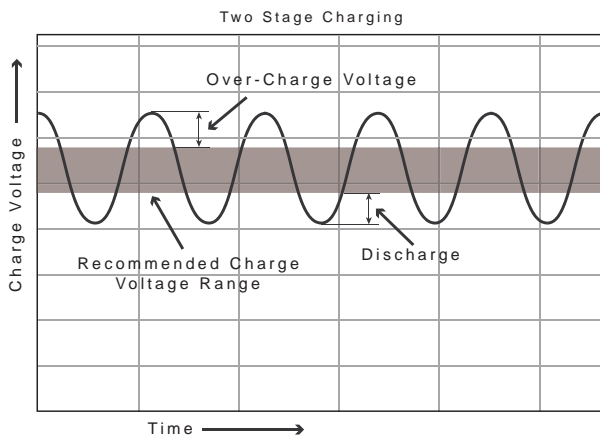

BATTERY LIFE

Battery life depends on a number of key factors. These include:

- Operating temperature of the battery
- Method of charging utilized
- Actual use of the product i.e.: float or cycle.

Float Service

The estimated life under float service is 5, 10 or 15 years depending on the specific model. The float service is effected by the temperature and other factors listed above. Also the number and depth of discharges of the battery will influence

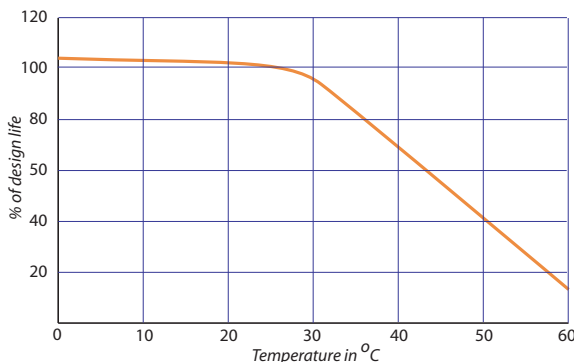

its functional life. Basically; the more discharges suffered and the deeper the discharges, the shorter the battery life

Cycle Service

Taking into consideration the above factors, the actual life of a battery in cycle service is dependent on the depth of discharge

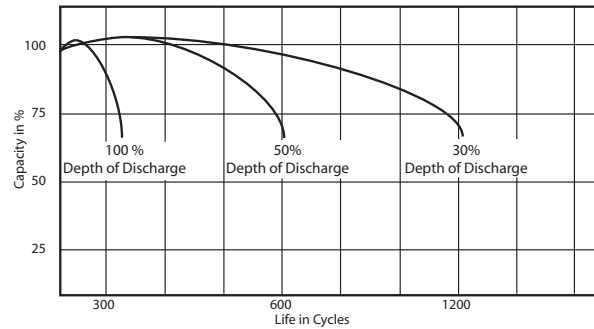

of each cycle. The greater the depth of discharge of each cycle, the fewer the number of cycles available from the battery.

Prolonging Battery Life

Charging instruction

1. Always recharge the battery as soon after use as possible whether or not it has been partially or fully discharged.
2. Constant voltage charging is recommended at 25°C, 2.27-2.30vpc for float use and 2.42 – 2.48Vpc for cycle use.
3. The maximum initial charging current should be 0.3CA.
4. If batteries are used in series or parallel, the correct size cabling should be used.
5. Do not charge the battery with reversed pole connection.
6. The battery requires between 110% and 117% of the total discharged energy to fully recharge.

Supplementary Charge Advice

1. Never leave a battery in a discharged condition.
2. Never allow a battery to fall below 2.1Vpc in storage. If the Voc is less than 2.1Vpc, the nominal battery capacity may not be achieved and the actual service life decreased.
3. Maximum continuous discharge current is 5CA. For greater continuous discharge currents please consult our technical staff.
4. Avoid over discharging the battery.
5. Stored batteries should receive a supplementary charge at the above-suggested intervals if they are to achieve their service design life.

Further consideration

Ensure the operating temperature is below 40°C.

Storage

1. When storing the batteries, be sure to remove them from the equipment or disconnect them from the charger and load. Keep them in a place where the air is dry and the temperature is sufficiently low.
2. Charge the batteries, at least once, every six months during storage.
3. The batteries gradually deteriorate even during storage.

Other Precautionary Measures

1. When cleaning the batteries, use soft cloth only. Use of organic solvents such as gasoline or thinner and application or adherence of oil to the batteries must be avoided. Do not clean the batteries using a dirty or an oily cloth. Also contact with PVC material must be avoided.
2. Batteries may generate flammable gas in some cases. Do not expose them to flame or excess heat. Do not short out batteries.
3. Do not attempt to disassemble the batteries. Avoid contact with sulphuric acid moisture that may leak from physically damaged batteries. If contact is made with skin or clothes, rinse the area generously with water. If contact is made

with the eyes, wash them thoroughly with large amounts of clean water, and consult a physician immediately.

4. Batteries can explode if put into a fire. Never dispose batteries in a fire.
5. Mixed usage of batteries differing in capacity, type, manufacturer or history of use (charge/discharge operation) may damage the batteries and the equipment due to the difference in their characteristic values. This practice must be avoided at all costs.
6. While our batteries are exceptionally dependable, we do not recommend use in life support medical applications unless there is an alternate battery or back-up power supply.
7. When the batteries come to their end of life, discharge duration time becomes drastically reduced. And finally, batteries lose their available capacity by internal short-circuit and/or dried out electrolyte. Therefore, please consider the design of the charger with regard to the above battery damage

Only use batteries of the same age and with the same history, differences in their production date and use can have effects on their internal resistance. When two batteries are parallelly connected, they receive the same voltage when connected to a charger. However, when one battery has a lower internal resistance, this will be fully charged before the other battery reaches it fully charged stage. Further charging will result in overcharging, loss of electrolyte and consequently reduced functional life.

When different batteries are placed in series the same charge current will flow through both batteries, however, the voltage over each battery will differ in accordance to the internal resistance. This could lead to over-voltage on one of the batteries, premature grid corrosion, heating and loss of electrolyte.

Connecting Batteries

When combining multiple batteries into a larger system only use batteries of the same capacity. Use wires of the correct diameter and ensure to tighten the connections to the batteries to the specified torque. Do not over-torque since this can damage the nuts, bolts and inserts and could also damage the epoxy sealing around the poles leading to electrolyte loss.

When connecting batteries in parallel or series & parallel ensure that the total cable length used in each string is equal. This because each cable has some resistance and should be equal in both strings. Use cable of equal diameter for each strings preferably from the same manufacturer. Cover the connectors with some white petroleum jelly to protect them against corrosion. Ensure that cables can not scuff against cabinets since this could damage the isolation over time and result in short circuits.

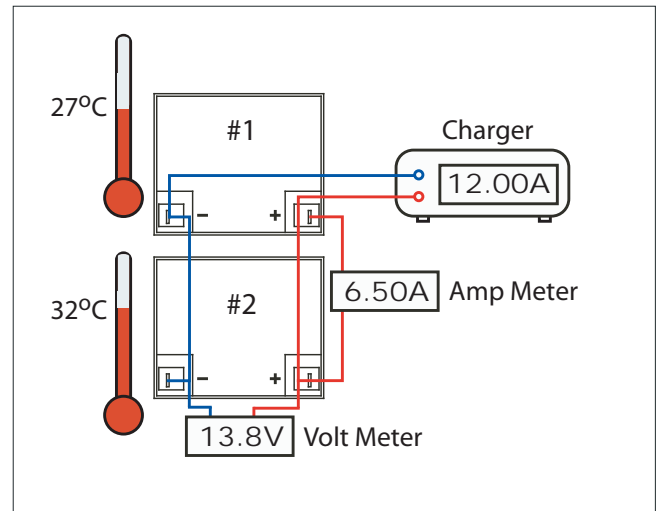

A parallel connection of batteries with different R_i values results in unequal currents through the batteries.

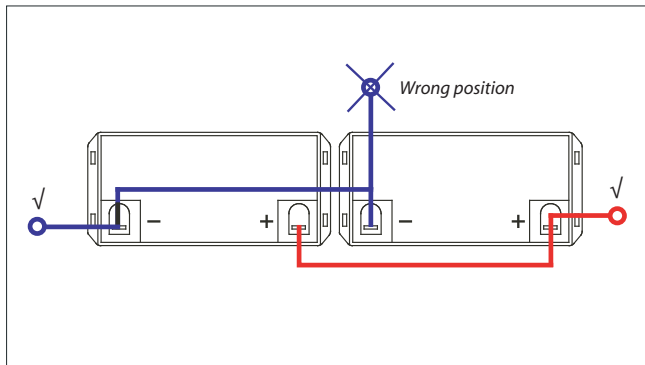

Parallel connection

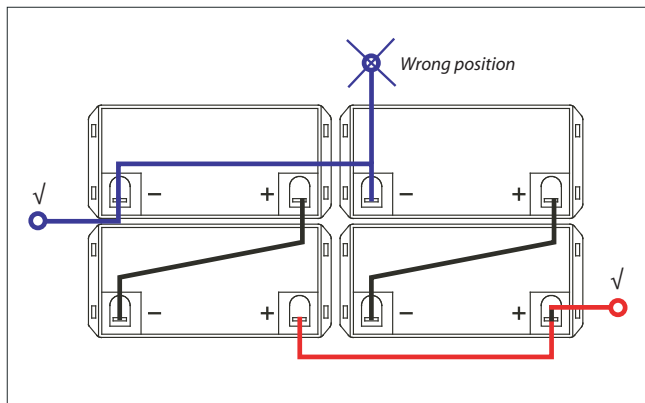

Series-parallel connection

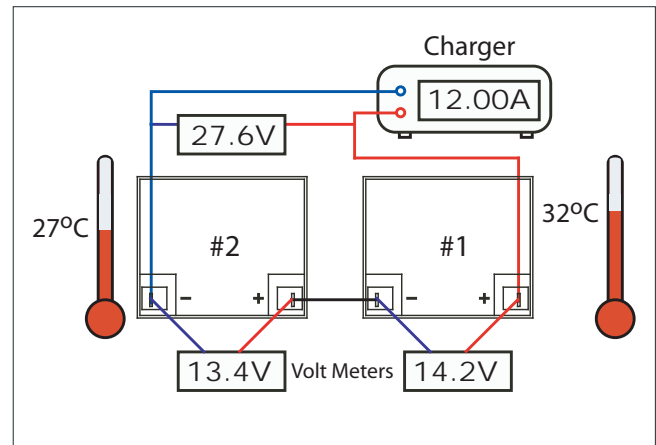

A series connection of batteries with different R_i values results in unequal voltages across the batteries.